

1394 PWG Model Overview

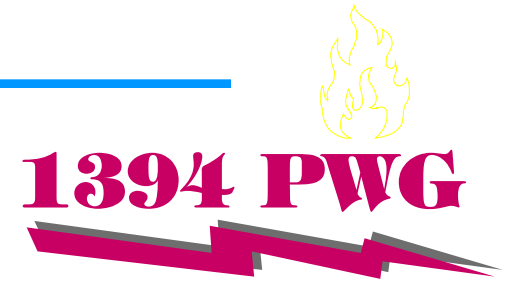

- How do we model Connections, Services, Functions, Luns and Logins?
- Topic has been discussed for many hours at many PWG meetings.
- Following will introduce a proposal to resolve this issue

Services, Functions, LUNs and Login Model

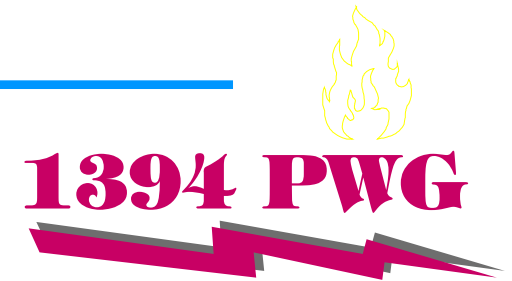

PC Host
Client

Peripheral
Server

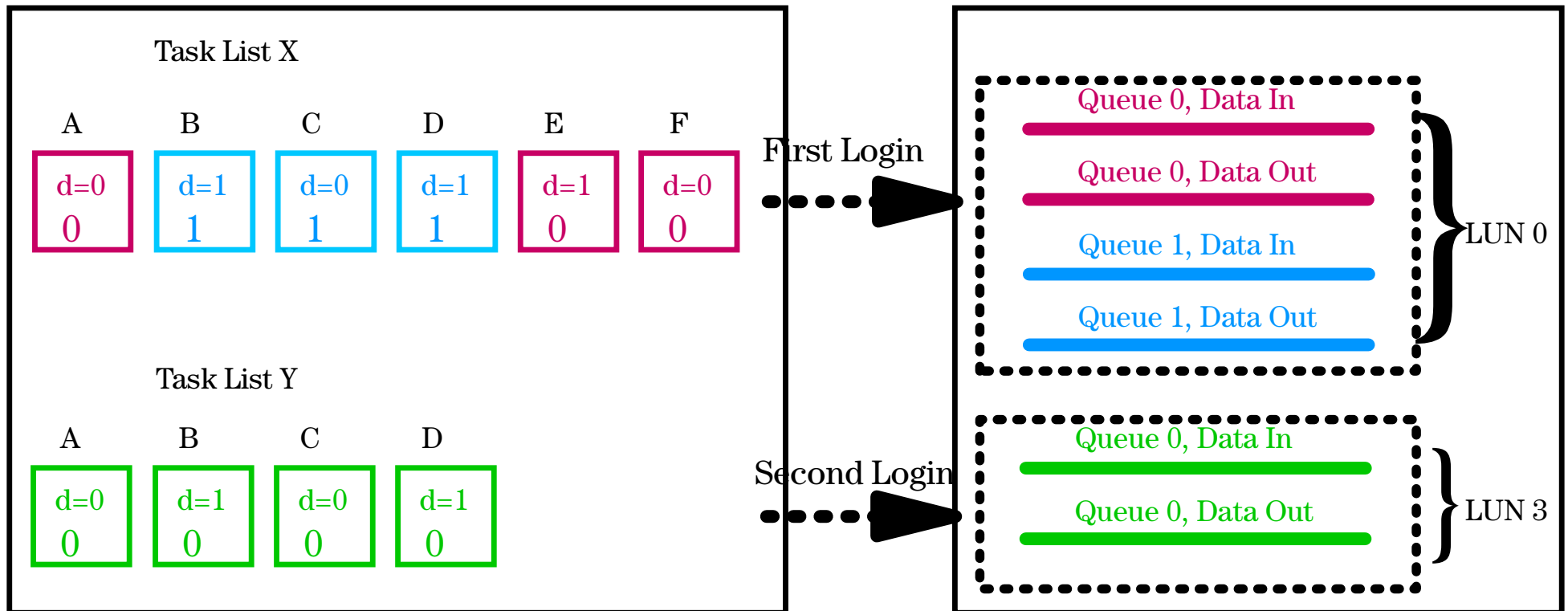

Services, Functions, LUNs and Login on the Target

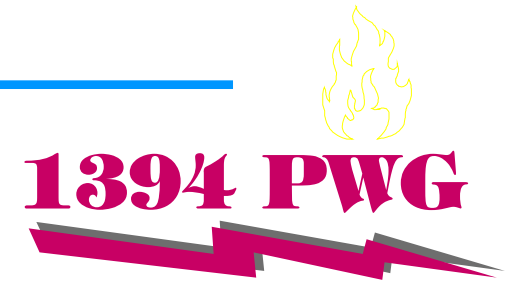

Peripheral Server

Unit Directory: Function=Printer

